

DILLON

SnapShot™ Single Column Motorized Test Stand

Like the click of a camera, The Dillon SnapShot™ allows you to capture a moment in time. It provides an accurate picture of how materials or products respond at any given point during compression or tension loading.

The SnapShot, coupled with a Dillon Force Gauge and good fixtures, constitutes a simple and economical, yet powerful testing system.

- 220lbf / 1,000 N / 100 kg load capacity
- Crosshead speed range from 0.5 – 19.7 in/min (12.5 – 500 mm/min)
- Single cycle test mode with full-speed crosshead return
- Auto-travel reverse on alarm point or sample break
- Headroom up to 13 in. (330 mm)
- Pre-setable upper & lower travel limits
- Indication of crosshead speed & travel direction
- CE marked





The SnapShot coupled with an Advanced Force Gauge, DataPlot software and a cable assembly, lets you download data to a PC in real time. This information can be saved and exported. This can be a particularly cost-effective option for routine tests.

Specifications

Load capacity: 220 lbf (100 kgf, 1,000 N)

Power consumption: 60 watts (maximum)

Weight (stand only): 39 lb (18kg)

Crosshead motion:

Travel range – 11.4 in (290 mm)

Maximum daylight – 17.3 in (440 mm)

Max. headroom (as illustrated) – 13.0 in (330 mm)

Speed range: 0.5 – 19.7 in/min (12.5 – 500 mm/min)

Speed accuracy: ±10% of indicated speed

Speed indicated on stand: Graduated dial

Direction of travel indicated on stand: By LED

Limit switch repeatability: <0.02 in (0.5 mm)

(With constant speed setting)

Over-run at top speed: <0.08 in (2 mm)

Operating modes: Manual, single cycle with full-speed crosshead return

Reverse on alarm point: Yes, with AFG or AFTI, and cable

Reverse on sample break: Yes, with AFG or AFTI, and cable

Accessories

Force gauge

S-beam loadcell, tension block module & AFTI

Reverse on alarm cable (AFG/AFTI to SnapShot)

DataPlot logging/plotting PC software

Anvil plate:

6.3 in (160 mm) x 3.94 in (100 mm)

Female threads $10/32$ " UNF, $5/16$ " UNC

Dimensions

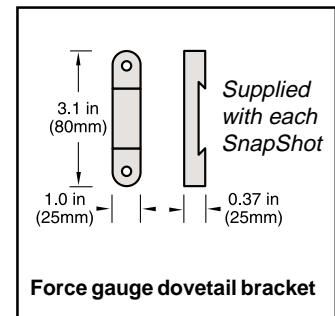
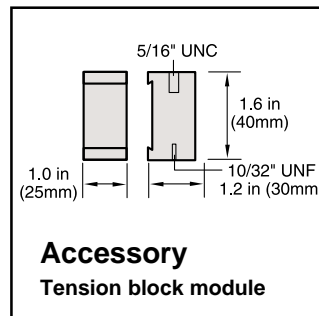
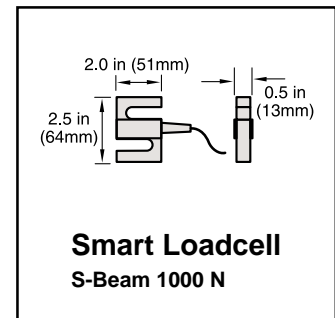
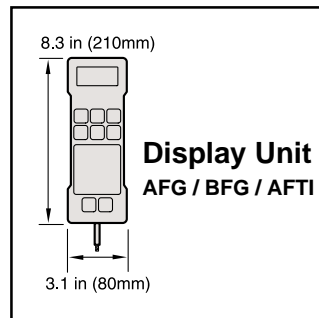
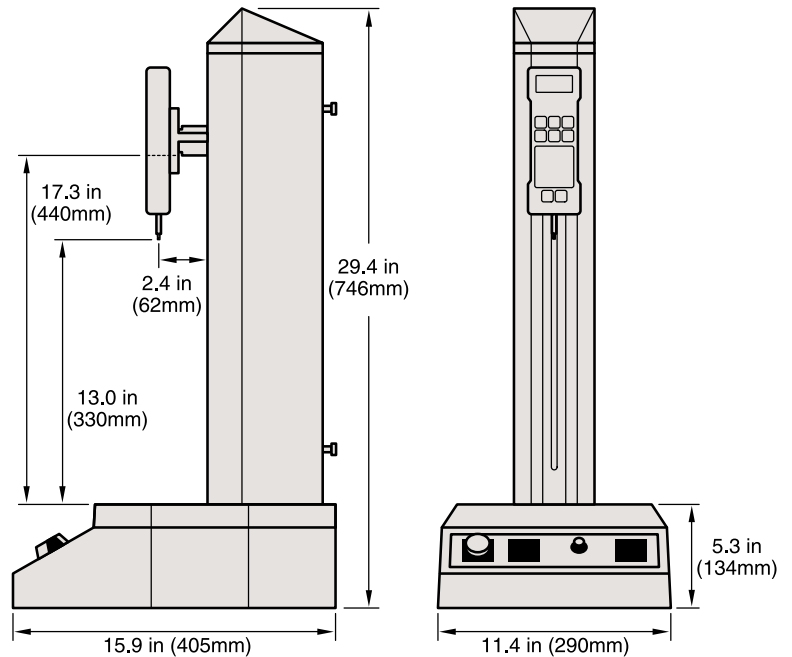

Dillon

A division of Weigh-Tronix Inc
1000 Armstrong Dr
Fairmont, MN 56031, USA
Telephone +1 507-238-4461
Facsimile +1 507-238-8258
e-mail: dillon@weigh-tronix.com
www.dillon-force.com

DILLON

Force Measurement Products & Systems